

Items Supplied >

- 1 - FRONT HEADPIPE W/HEATSHIELD
- 1 - REAR HEADPIPE W/HEATSHIELD
- 1 - MUFFLER ASSEMBLY
- 1 - EXHAUST BRACKET
- 1 - REGULATOR BRACKET
- 5 - HOSE CLAMPS (Speedster short pipes only)
- 6 - HOSE CLAMPS (Speedster long pipes only)
- 1 - CLAMP, 27-61MSC
- 3 - BOLT, HEX 5/16-18 x .63
- 2 - SCREW, BUTTON ¼-20 x .38
- 1 - M10 Bolt
- 1 - M10 Nut
- 1 - M10 Flat Washer

Application(s) >

HONDA VTX1800C/N/R/S/F 02-Up

Instruction Manual >

1725/1726/1925/1926

Page 1 of 2

PRIOR TO INSTALLATION, MAKE SURE YOUR STOCK HEADPIPE GASKETS ARE IN GOOD SHAPE. IF YOU HAVE ANY DOUBTS AS TO THEIR CONDITION, REPLACE THEM.

Read all instructions carefully and completely before installing your new exhaust system

1. Remove your stock exhaust system and large muffler bracket. Remove regulator from stock exhaust bracket but leave wiring harness connected. Mount the regulator to supplied regulator bracket as shown in fig. 1. Use supplied 3/8" x 1" bolt to secure to frame as shown in fig. 1.

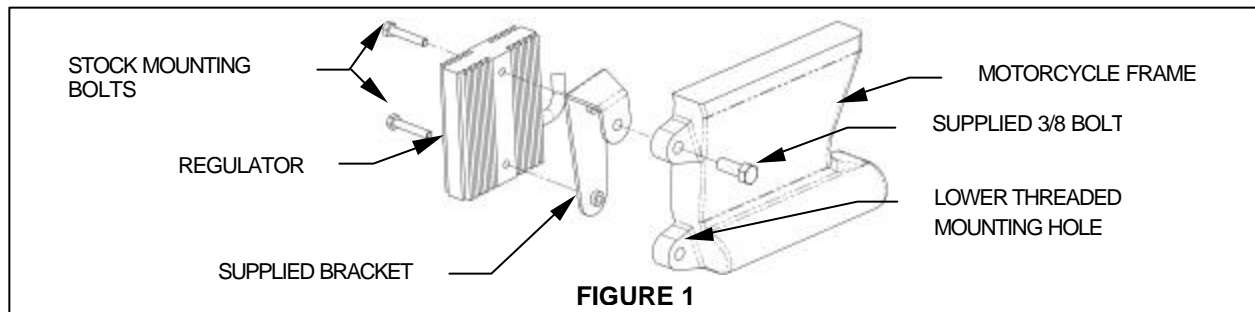

2. Remove exhaust mounting bracket from the box. Line up bottom hole of mounting bracket with the threaded mounting hole on the frame (refer to fig. 1) and install supplied M10 fine thread bolt and M10 flat washer but do not tighten. **Note:** Make sure 10mm bolt threads into frame prior to installation to avoid damage to threads.
3. Loosen the right front footpeg/ floorboard assembly to help provide installation clearance for the front head pipe (Note: on the VTX1800C/F models remove the rear brake reservoir from the frame. **DO NOT** disconnect the reservoir hose. Move the reservoir, still connected to the hose, aside for additional clearance.
4. Slide the supplied exhaust flange over the front head pipe and bolt to cylinder using stock hardware. **DO NOT TIGHTEN** at this time.
5. Place the supplied clamp 27-61msc onto the muffler assembly and slide the muffler assembly over the front headpipe and bolt it to the rear cylinder using the stock hardware. (NOTE: If the muffler clamp is slid past the slots on the pipe the clamp will no tighten.)
6. Bolt the muffler assembly to the mounting bracket using the supplied 5/16 bolts. **DO NOT TIGHTEN** at this time.

*** Cobra recommends you always wear a helmet while riding. Please never operate your motorcycle while under the influence of alcohol and/or drugs. Enjoy the new look of your motorcycle and please ride safely.**

7. Make sure the front headpipe is inserted properly into the rear assembly and make sure the pipes are parallel to each other and the ground. Tighten the bar mount to the frame first, then the front and rear cylinder bolts, then the mufflers to the mounting bar.
8. Unscrew the remaining hose clamps and feed the tail end of the clamp through the clips on the inside of the heat shields. The screw end of the hose clamp should be accessible for tightening but not visible when the heat shields are mounted to the pipes.
9. To install the front heatshield, first slide the rear portion of the heatshield over the muffler, continue to slowly slide it forward pushing the front and middle of the heatshield, near the power port cutout, gently into place between the frame and motor (Hint: Spread the hose clamps apart slightly to make it easier to slide them over the muffler assembly and head pipes) and be very careful not to twist the heatshield at the power port cutout or you may damage the heat shield. Make sure the muffler clamp doesn't interfere with the heatshields and are aligned as shown in figure 2. Snug the heatshield clamps but **DO NOT TIGHTEN**.
10. Install the rear heatshield the same way as the front heatshield.
11. Make sure the front and rear heatshields are even on the back with each other. Install one billet tip on each heatshield. Fasten the tips with the supplied 1/4-20 screws making sure they snug up against the heatshield leaving no gap between the tip and heatshield when tighten. **If it is difficult to slide the tips into the heatshields loosen the clamps on the heatshield, failure to do this may cause damage to the chrome tips.**
12. Tighten the clamps on the heatshields making sure the ends of the shields are even.
13. Reinstall the right front footpeg/floorboard assembly and tighten bolts to factory specifications. If you removed the brake reservoir in step 3 reattach it with the stock hardware and tighten to factory specifications.
14. Make sure all the hardware (brackets, headpipes, heatshields, mufflers and tips) has been tightened appropriately before starting your motorcycle.

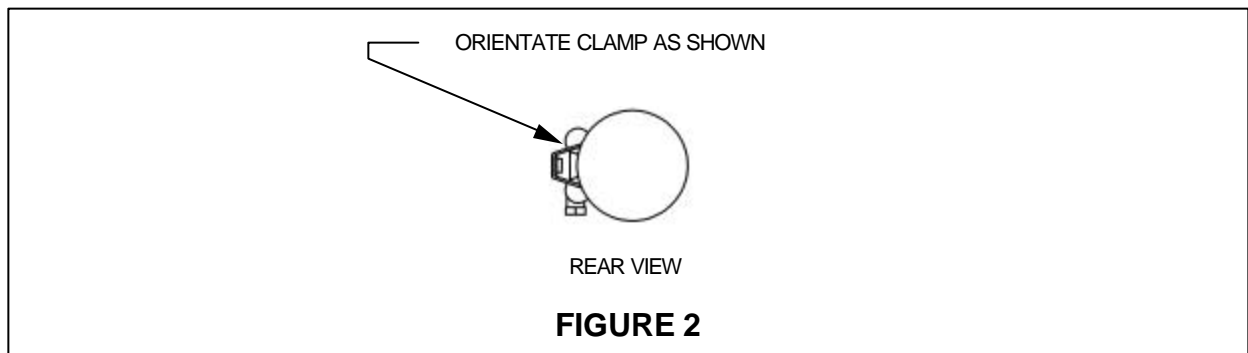

Important: It is recommended that you install a Cobra Fi2000 Digital Fuel Processor with your Cobra exhaust system. Cobra is not responsible for the performance of any other fuel management system used with Cobra exhaust systems. **VTX1800C/R/S 92-0650, VTX1800F 92-0651, VTX1800N 92-0655**

Before starting your engine remove all fingerprints from chrome with a quality wax or chrome polish. Failure to do so can cause discoloration. Due to fluctuations in carburetor settings, timing, etc., Cobra Engineering does not warrant against chrome discoloration.