

Items Supplied >

1 – FRONT HEADPIPE W/HEATSHIELD
1 – REAR HEADPIPE W/HEATSHIELD
1 – MUFFLER ASSEMBLY
1 – EXHAUST BRACKET
2 – EXHAUST FLANGES
4 – HOSE CLAMPS
2 – CLAMP, 27-61MSC
2 – BOLT, HEX 5/16-18 x .63
2 – SCREW, BUTTON ¼-20 x .38
2 – BOLT, ALLEN M10x30mm
2 – NUT, M10 NYLOCK
2 – BILLET MUFFLER TIPS

Application(s) >

YAMAHA ROADSTAR 1600/1700 99-Up

Instruction Manual >

2721 / 2921

Page 1 of 2

PRIOR TO INSTALLATION, MAKE SURE YOUR STOCK HEADPIPE GASKETS ARE IN GOOD SHAPE. IF YOU HAVE ANY DOUBTS AS TO THEIR CONDITION, REPLACE THEM.

Read all instructions carefully and completely before installing your new exhaust system

1. Loosen and move the right side floorboard out of the way to ease installation of the exhaust.
2. Remove stock exhaust system.
3. Remove the stock exhaust mounting bracket. NOTE: The bracket brake line guide must be cut and spread apart so you can remove the brake line from the bracket. Refer to Figure 1.
4. Install the new exhaust mounting bracket using the supplied M10 hex bolts and nylock hex nuts but **DO NOT TIGHTEN** at this time. Connect the brake hose clip to the bracket using the stock M6 bolt. Refer to Figure 2.
5. Install the front and rear head pipes onto motorcycle using the supplied flanges, stock bolts and stock nuts. Make sure pipes are parallel to each other.
6. Remove the muffler assembly from the box and slide two supplied 27-61MSC clamps onto the back muffler tubes. Refer to figure 1 for alignment.
7. Slide the muffler assembly onto the head pipes by tapping on the head pipes with your hand as you push the mufflers forward making sure the assembly slides as far forward as possible. Secure the muffler assembly to the mounting bracket using the supplied 5/16-18 bolts but **DO NOT TIGHTEN**.
8. Make sure the muffler assembly is parallel to the ground (this is critical) then tighten the following in order, muffler bracket to the frame, muffler assembly to the muffler bracket, head pipe flanges to the motor (slowly tighten opposing nut) and muffler clamps. (NOTE: If the muffler clamps are slid to far up the muffler or past the three slots, the clamps will not tighten.)
9. Unscrew the remaining hose clamps and feed the tail end of the clamp through the clips on the inside of the heat shields. The screw end of the hose clamp should be accessible for tightening but not visible when the heat shields are mounted to the pipes.
10. To install the front heatshield, first slide the rear portion of the heatshield over the muffler, continue to slowly slide it forward pushing the front of the shield gently into place between the frame and motor (Hint: Spread the hose clamps apart slightly to make it easier to slide them over the muffler assembly and head pipes). Make sure the muffler clamps don't interfere with the heatshields and are aligned as shown in figure 1. Snug the heatshield clamps but **DO NOT TIGHTEN**.
11. Install the rear heatshield the same way as the front heatshield.

** Cobra recommends you always wear a helmet while riding. Please never operate your motorcycle while under the influence of alcohol and/or drugs. Enjoy the new look of your motorcycle and please ride safely.*

12. Make sure the front and rear heatshields are even on the back with each other. Install one billet tip on each heatshield. Fasten the tips with the supplied ¼-20 screws making sure they snug up against the heatshield leaving no gap between the tip and heatshield when tighten. **If it is difficult to slide the tips into the heatshields loosen the clamps on the heatshield, failure to do this may cause damage to the chrome tips.**
13. Tighten the clamps on the heatshields.
14. Retighten the floorboard mount loosened in step 1.
15. Make sure all the hardware (brackets, headpipes, heatshields, mufflers and baffles) has been tightened appropriately and cleaned before starting your motorcycle.

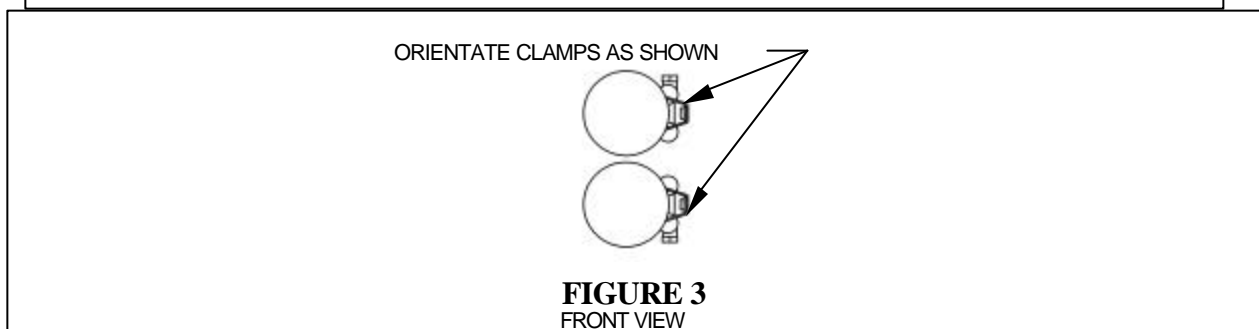
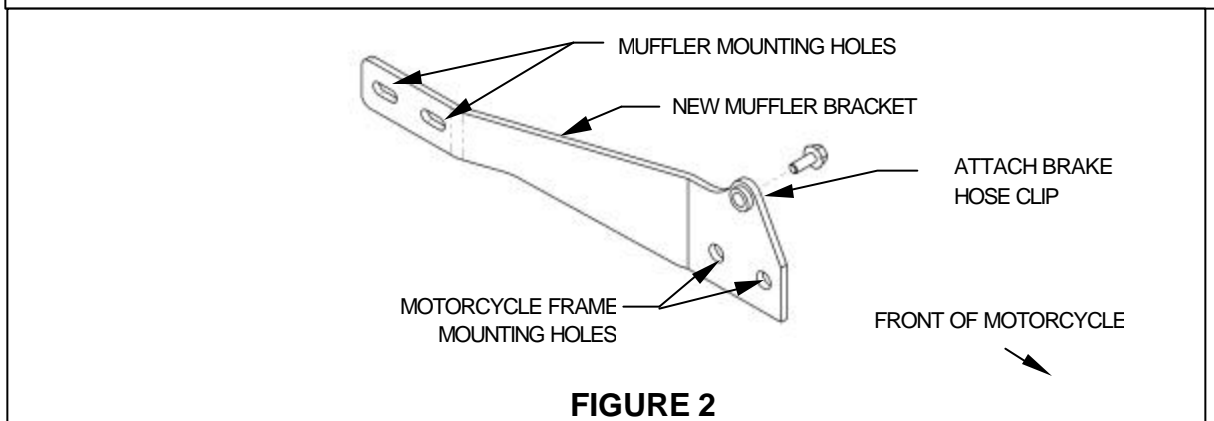
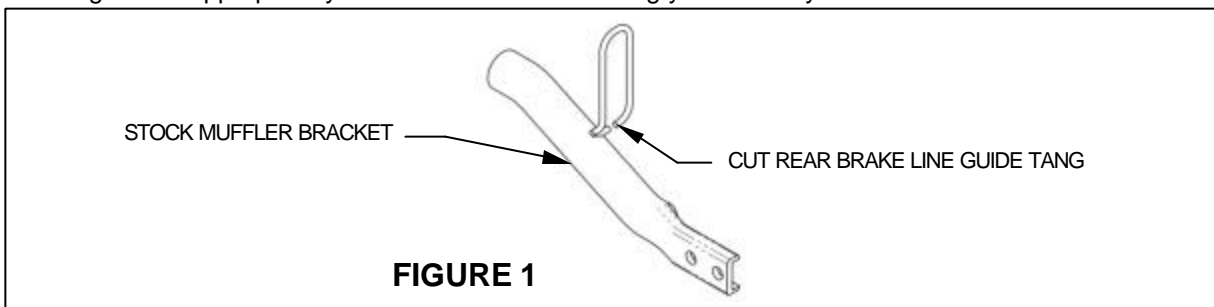

IMPORTANT: It is recommended that you re-jet your bike with a Cobra Jet Kit, available from Cobra. RoadStar 1600 part #92-2271, RoadStar 1700 part #92-2272.

Before starting your engine remove all fingerprints from chrome with a quality wax or chrome polish. Failure to do so can cause discoloration. Due to fluctuations in carburetor settings, timing, etc., Cobra Engineering does not warrant against chrome discoloration.